

Formulate Designer Series 10' Backwall - Kit 08

FMLT-DS-10-08

Formulate® Designer Series 10ft displays have unique stylistic features and shapes, are portable and easy to assemble. The aluminum tube frame features snap-buttons and/ or spigot connections and zipper pillowcase fabric graphics. All displays come in portable, wheeled transit cases. Simply pull the pillowcase fabric graphic(s) over the frame and zip.



features and benefits:

- Premium aluminum tube frames with snap button / spigot assembly
- Easy to store and ship
- Quick to set up
- Weighted feet for added stability
- Two zipper pillowcase fabric graphics for walls and two zipper pillowcase graphics for canopy
- Kit includes: monitor kiosk featuring a medium monitor mount, can hold 32-55" monitor/ max weight 40lbs
- Lifetime limited hardware warranty against manufacturer defects

dimensions:

Hardware

Assembled unit:
114.59" w x 97.41" h x 37.09" d
2911mm(w) x 2474mm(h) x 942mm(d)

Approximate weight with cases:
196 lbs / 88.9 kgs

Shipping

Packing case(s):
3 OCE Cases

Shipping dimensions:
OCE: Expandable case length (l) may vary
40" - 66" l x 18" w x 18" h
1016mm-1677mm(l) x 458mm(w) x 458mm(h)

Approximate total shipping weight
(includes cases & graphics):
213 lbs / 96.6 kgs

Graphic

Refer to related graphic template for more information.

Visit:
www.exhibitors-handbook.com/graphic-templates

additional information:

Graphic material:
dye-sublimation zipper pillowcase fabric

We are continually improving and modifying our product range and reserve the right to vary the specifications without prior notice. All dimensions and weights quoted are approximate and we accept no responsibility for variance. E&OE. See Graphic Templates for graphic bleed specifications.

Included In Your Kit

Tools, Components, & Connectors



ALLEN KEY SET x1



ES50 x6



LN114-SCRW x2



TC-30-A-90 x2



TC-30-A x1



LN114-S2-450 x1



TC-30-90T x4



TC-30-90B x1

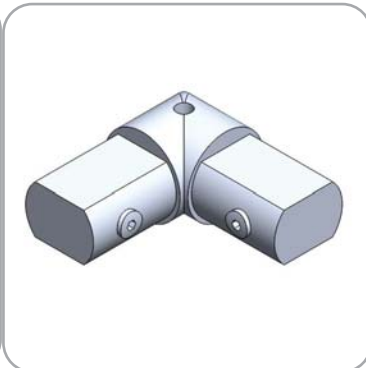

ES50-2W x1

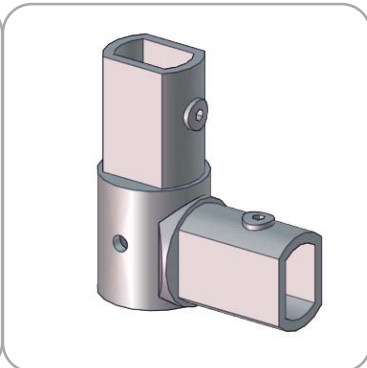

ES50-C ES50-I x1



LN114-S2-650 x1



PM4S3-MK-M x1

Included In Your Kit

Graphics

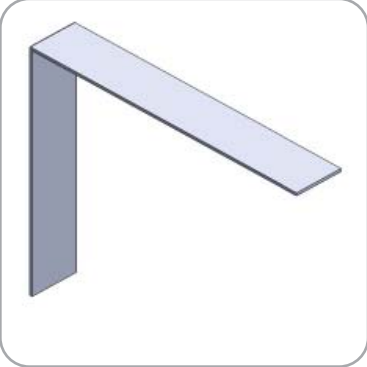

FMLT-DS-10-08-A-G x1

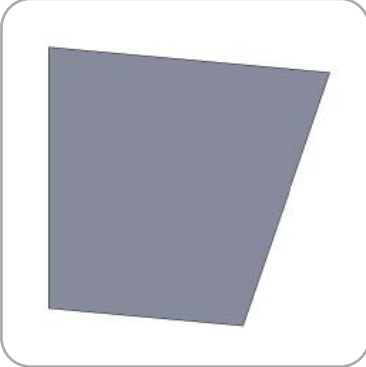

FMLT-DS-10-08-B-G x1

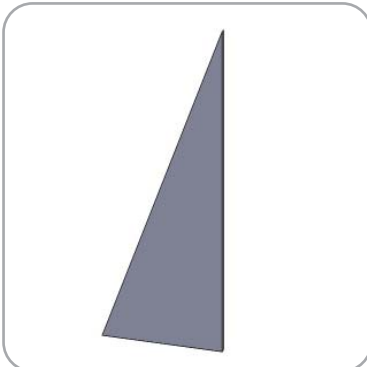

FMLT-DS-10-08-C-G x1

Included In Your Kit

Tubes



DS-10-08-A-T1 x6



DS-10-08-A-T2 x2



DS-10-08-A-T3 x2

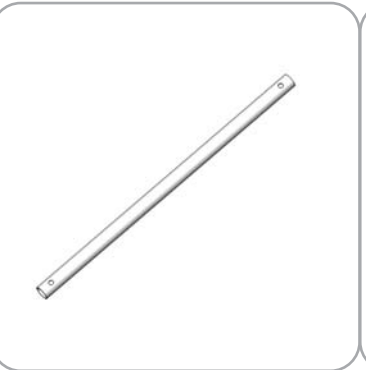

DS-10-08-A-T4 x3



DS-10-08-A-T5 x2



DS-10-08-A-T6 x2



DS-10-08-B-T1 x1



DS-10-08-B-T2 x3



DS-10-08-B-T3 x1

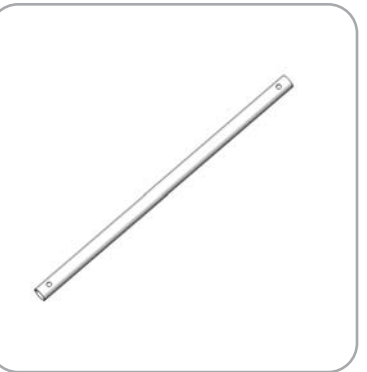

DS-10-08-B-T4 x3

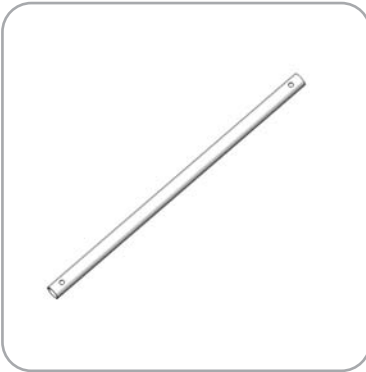

DS-10-08-C-T1 x1



DS-10-08-C-T2 x2



DS-10-08-C-T3 x1



DS-10-08-C-T4 x1



DS-10-08-C-T5 x1

Exploded View

FMLT-DS-10-08

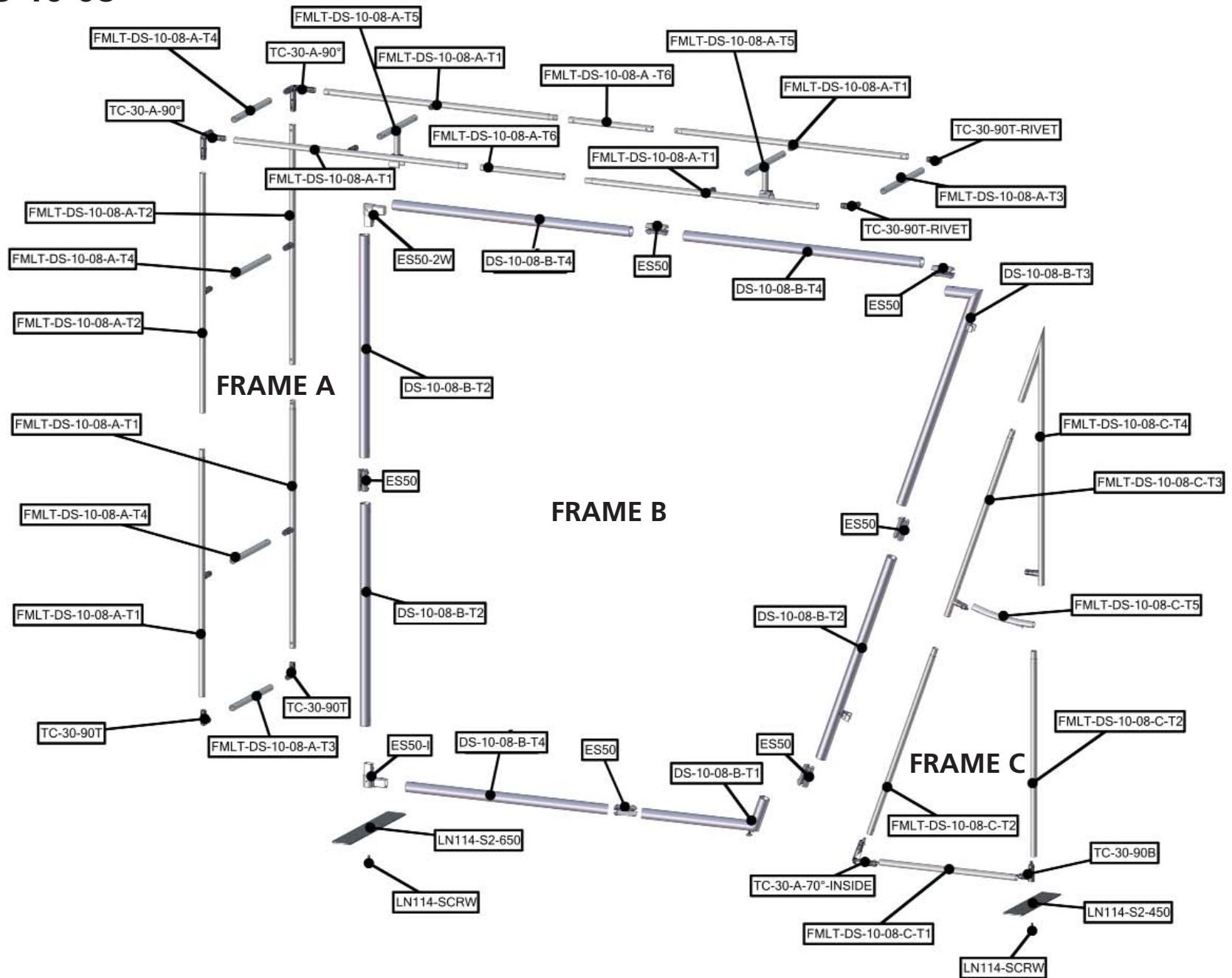

Labeling Diagram

FMLT-DS-10-08

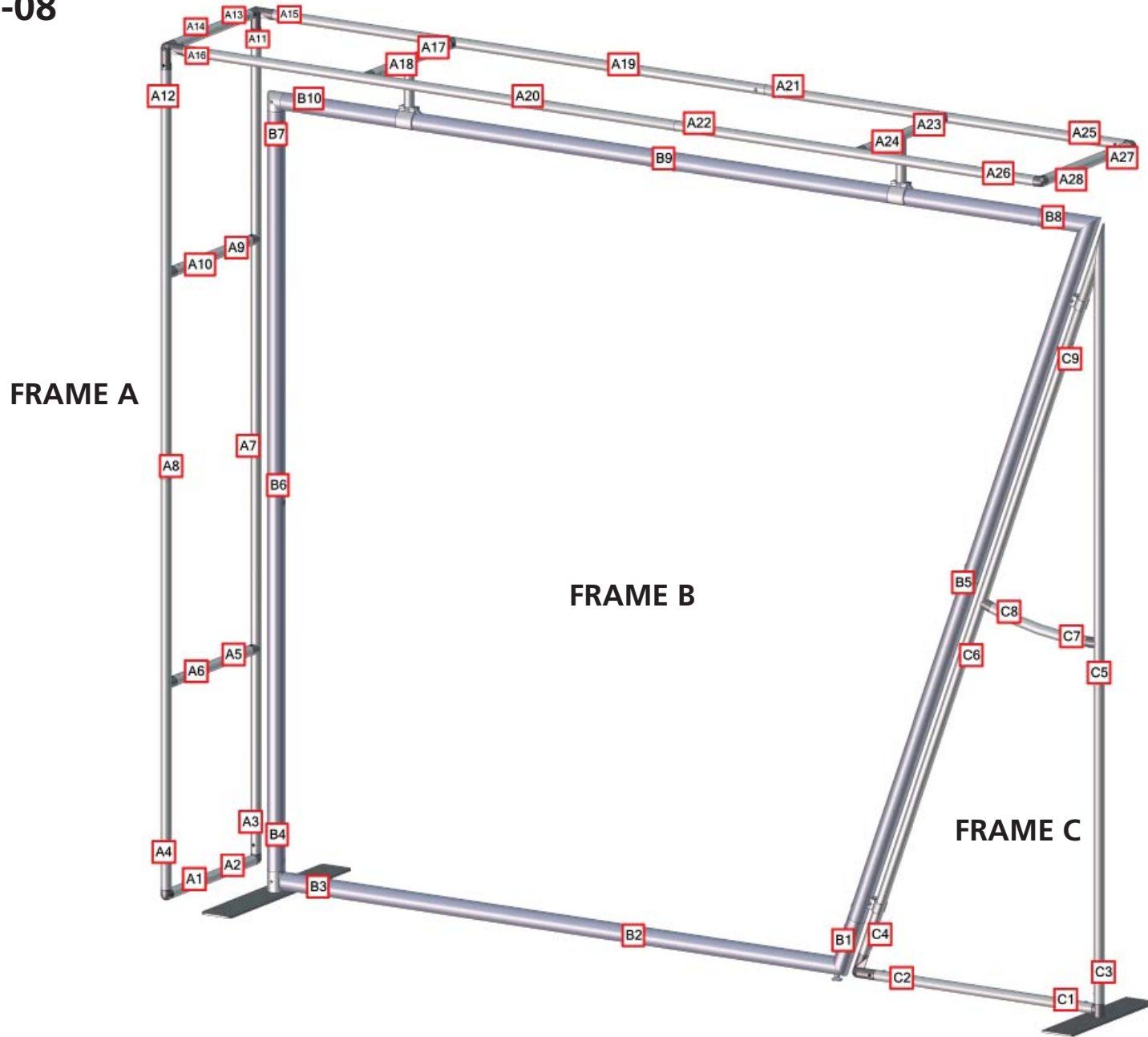

Connection Methods

Formulate™ structures use a number of different yet simple connection methods. Your kit will include one or more of the connection methods shown below. Steps within the Kit Assembly will reference a specific method for each connection point.

Connection Method 1: ES30 / ES50 / ES75

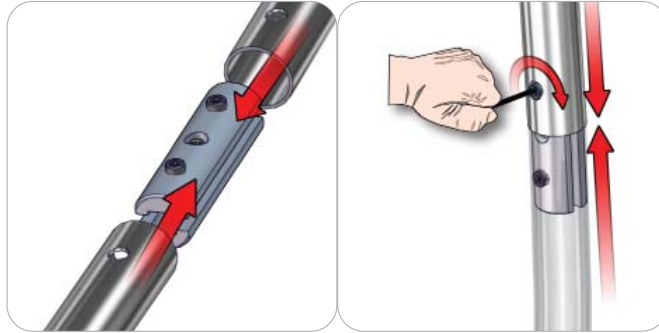

Compress the unlocked connector and slide one tube onto each end. Lock both screws carefully using your allen key tool. Be sure to lock securely, but do not overtighten.

Connection Method 2: Snap Buttons & Swage

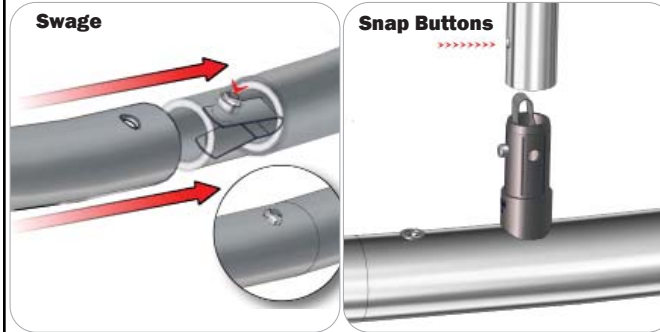

Locate the snap button on the connector or swage tube. Locate the hole on the corresponding tube. Press the snap button with your thumb and slide the tube and connector together so that the snap button snaps fully into the lock hole. To disassemble, press the snap button and pull apart.

Connection Method 3: ES30-90B / ES30-I / ES30-C

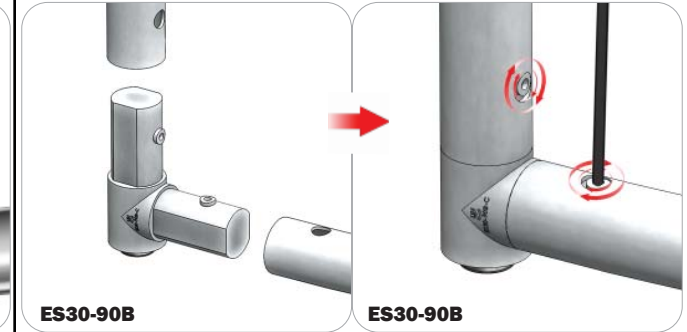

Compress one unlocked end of the connector and slide it through one tube end. Compress the other end of the connector and slide the second tube on. Lock both screws carefully using your allen key tool. Be sure to lock securely, but do not overtighten.

Connection Method 4: Tube Clamps

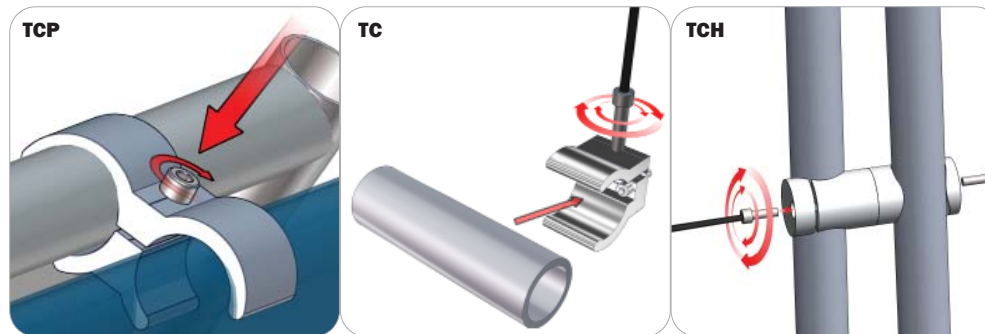

Be sure to fully assemble all frames before using clamps. With the clamp unlocked, place one tube of the first frame into the mouth of the clamp. Place the second tube (if applicable) into the second mouth of the clamp. With both frame's tubes in the clamp, be sure to lock securely, but do not overtighten.

Kit Assembly

Step by Step

Step 1.

Locate the components necessary for assembling Frame B. Assemble your frame in order according to the Labeling Diagram.

Please reference Connection Methods 1 and 3 for more details

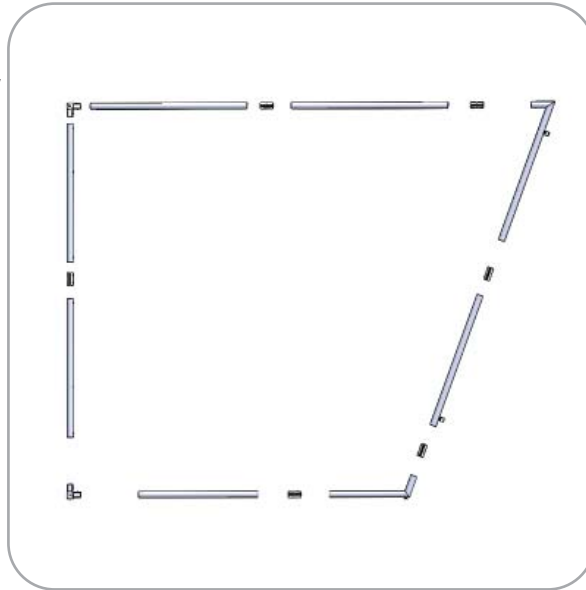
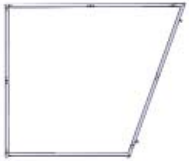

Step 2.

Fit Graphic B onto Frame B. For ease of installation, pull the fabric cover over the top left of the frame toward the bottom right while the frame rests flat on the floor. Zip to enclose.

Zipper located to the left side and bottom of Graphic B.



Step 3.

Gather a LN114-S2-650, and a LN114 screw. Attach the foot to the left (straight) side of Frame B.

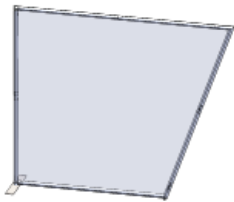

Step 4.

Locate the components necessary for assembling Frame C. Assemble your frame in order according to the Labeling Diagram.

Please reference Connection Methods 2 for more details

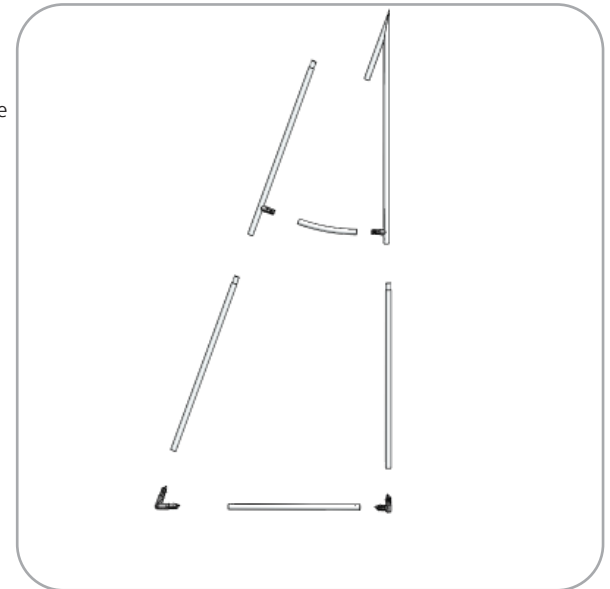

Kit Assembly

Step by Step

Step 5.

Fit Graphic C onto Frame C. For ease of installation, pull the fabric cover over the top of the frame while the frame rests flat on the floor. Zip to enclose.

Zipper located to the bottom of Graphic C

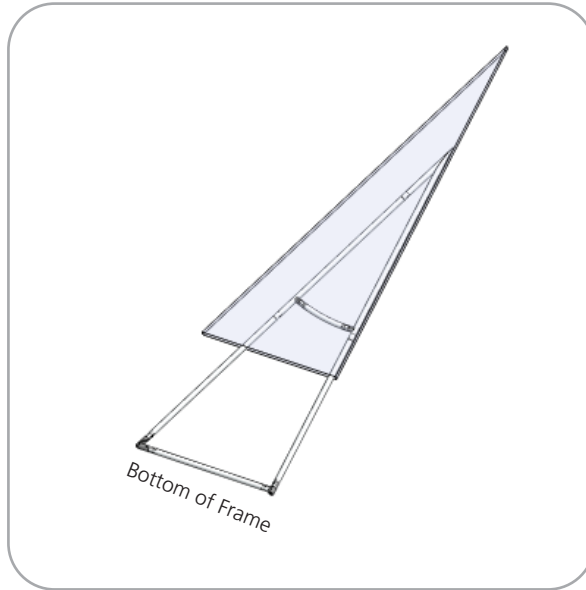

Step 6.

Gather a LN114-S2-450, and a LN114 screw. Attach the foot to the right (straight) side of Frame C.

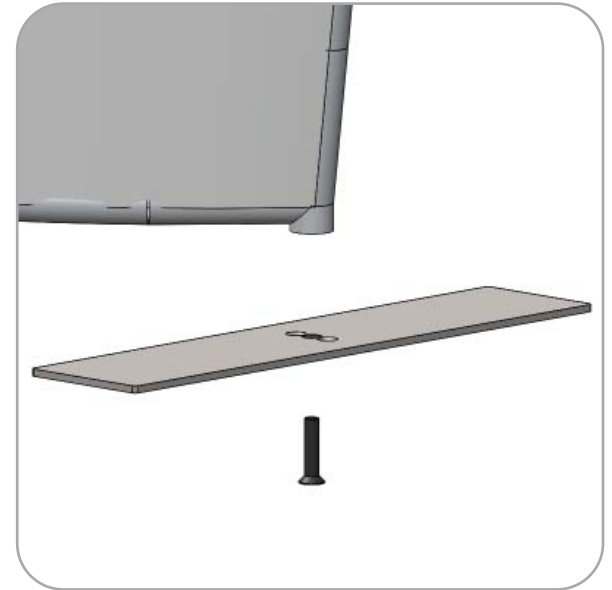
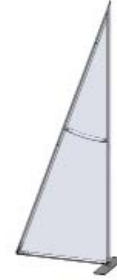

Step 8.

Locate the components necessary for assembling Frame A. Assemble your frame in order according to the Labeling Diagram.

Please reference Connection Methods 2 for more details

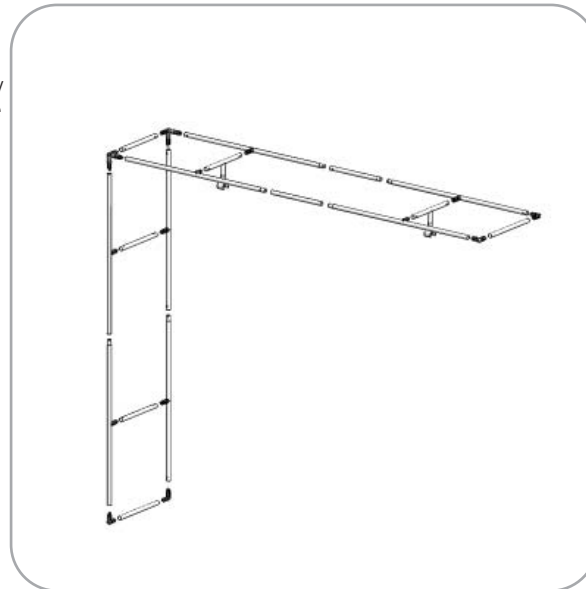
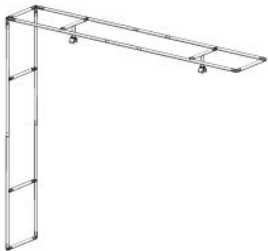

Step 7.

Fit Graphic A onto Frame A. For ease of installation, pull the fabric cover up from the bottom of the frame while the frame rests flat on the floor. Zip to enclose.

Zipper located to the back side of Graphic A



Kit Assembly

Step by Step

Step 9.

Assemble the kit by connecting each frame by there clamps. Tighten with your provided allen key tool.

Please reference Connection Methods 4 for more details

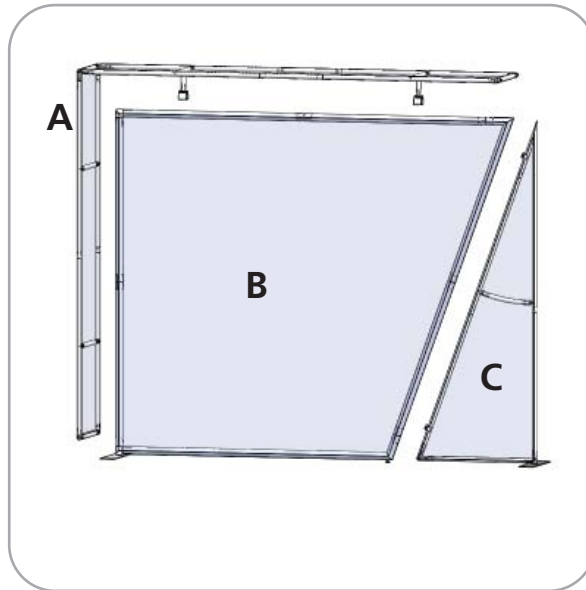
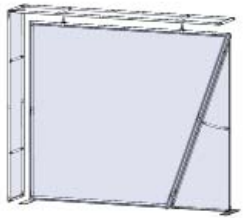

Step 10.

Place your monitor stand (*Reference the PM4S3-MK-M Kit here and related Instructions*) behind Frame B. Attach your monitor bracket to the stand through the front holes of the graphic.

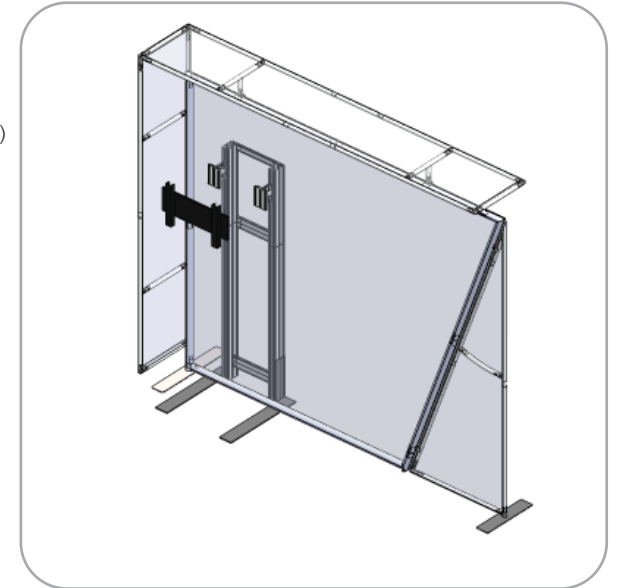
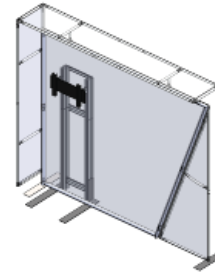

PM4S3 Monitor Kiosk

PM4S3-MK-M
PM4S3-MK-L

Kiosk displays are portable and easy to assemble. The aluminum extrusion frame features cam locks, tension glide connections and medium or large monitor mounts. This kiosk comes in a expandable shipping case.



features and benefits:

- Premium aluminum extrusion frames with cam lock and tension glide assembly
- Easy to store and ship
- Quick to set up
- Weighted feet for added stability
- Kiosk Kit includes a medium or large monitor mount
- Lifetime limited hardware warranty against manufacturer defects

dimensions:

Hardware	Shipping
Assembled unit: Medium or Large 25.59" w x 70.87" h x 25.59" d 650mm(w) x 1800mm(h) x 650mm(d) Approximate weight: (excludes cases & monitor mount) Medium or Large 40 lbs / 19 kgs	Packing case(s): Medium or Large 1 OCE Case Shipping dimensions: OCE: Expandable case length (l) may vary 40" - 66" l x 18" w x 18" h 1016mm-1677mm(l) x 458mm(w) x 458mm(h) Approximate total shipping weight: (includes cases & monitor mount) Medium 83 lbs / 38 kgs Large 85 lbs / 39 kgs

additional information:

- Medium monitor mount can hold 32-55" monitor/ max weight 40lbs
- Large monitor mount can hold 40"-65" monitor/ max weight 40lbs
- Monitor not included
- If shipping with backwall kit cases may vary

We are continually improving and modifying our product range and reserve the right to vary the specifications without prior notice. All dimensions and weights quoted are approximate and we accept no responsibility for variance. E&OE.

Included In Your PM4S3 Monitor Kiosk

Tools, Components, Connectors & Extrusions



5MM ALLEN-T x1



PM4S3-MM-FOOT-L x1



PM4S3-MM-FOOT-R x1



LN100 x4

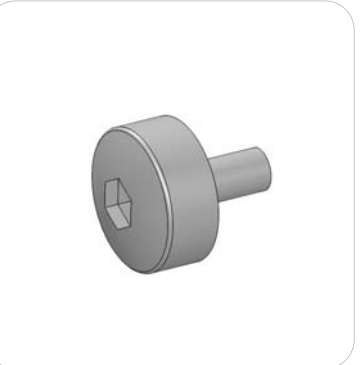

M5 THUMBSCREW x8



PH2-350-L-L x1



PS2-350-S-S-OUT x1



PH-350-L-L x1



PH5-100-L-L x2



PM4S4-150 x2



PM4S3-600-A165-A165 x2



PM4S3-1200-A165-A165 x2



PH2-300-TG x2



EXT-M-MB (or) EXT-LG-MB x1
Fastening Hardware Included

Exploded View

PM4S3-MK-M PM4S3-MK-L

Please note:
This is the the kiosk frame build for
either medium or large kit.

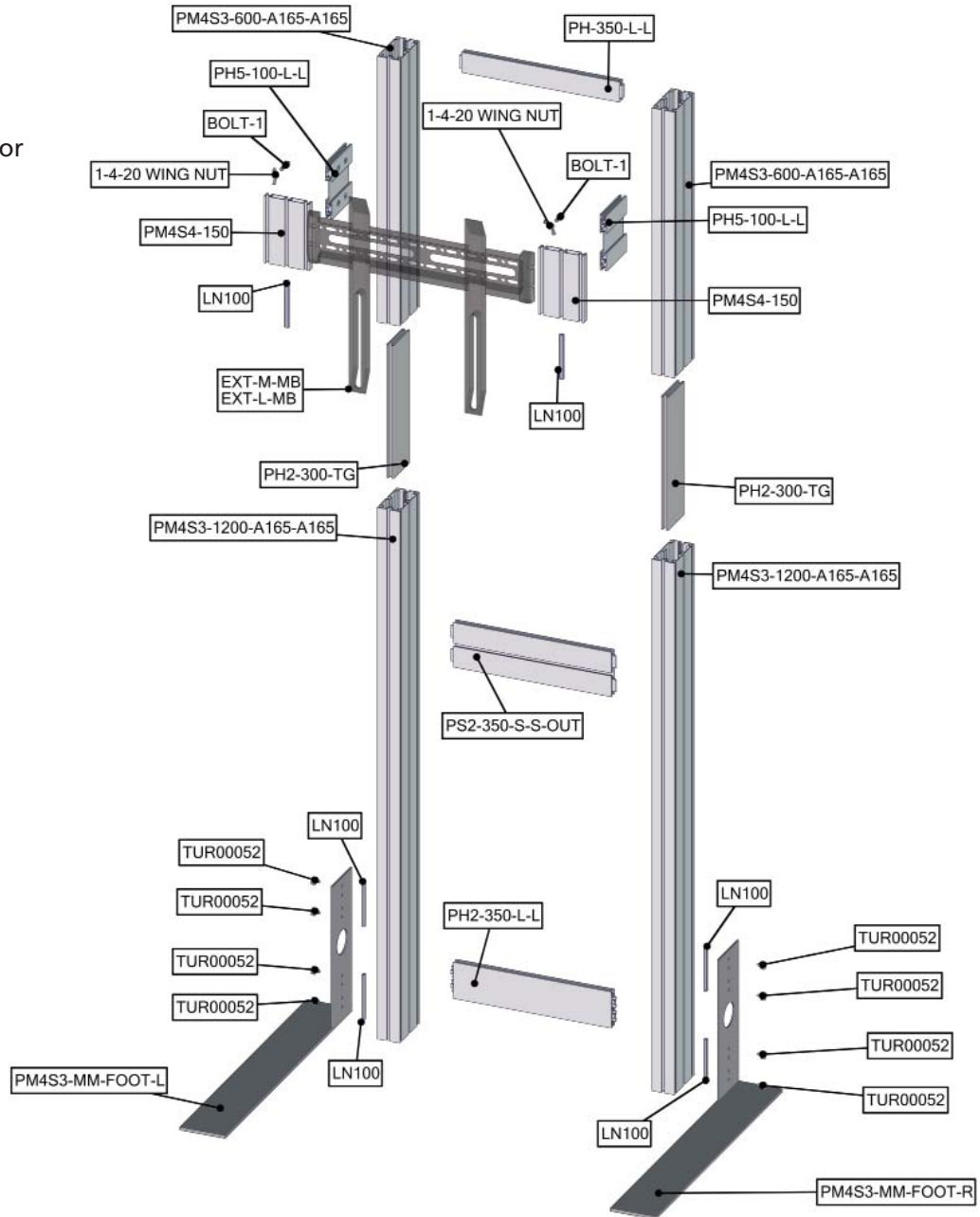

Kit Assembly

Step by Step

Step 1.

Reference the image to the right. Locate the coded extrusions. Slide the PH2-300-TG connector into one end of the PM4S3-1200-A165-A165 so that it goes as deep as the internal pins. Connect the PM4S3-600-A165-A165 by sliding it over the PH2-300-TG. Repeat for this step for the second vertical.

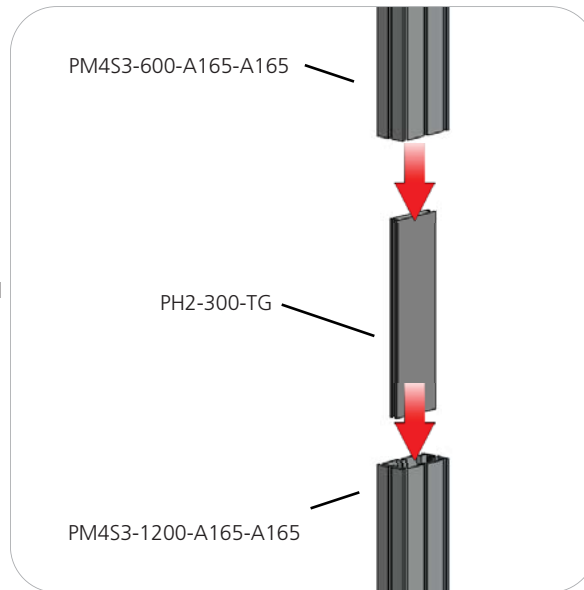

Step 2.

Collect your extrusions and handtool. Using the provided handtool, lock the extrusions into the back channel of the three channel PM4S3 faces as shown in the image below. Be sure the locks face toward the back of the assembly and do not over tighten.

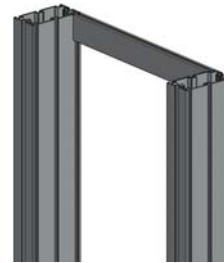

Step 3.

Locate the M5 thumbscrews, LN100s, and the PM4S3-MM stabilizing bases. Slide the LN100s into the middle channel of the PM4S3. Hand screw the M5 thumbscrews through the base holes and into the LN100 holes. Use the handtool to securely fasten the M5 Thumbscrews. Do not over tighten.

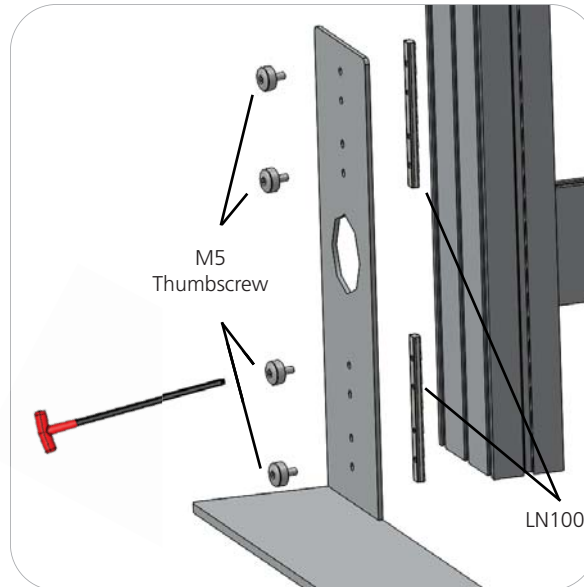

Step 4.

Measure from the ground to the center of the hole in your main kit's graphic. Lock the center of your PH5-100-L-L into the PM4S3 stacks at the dimension height of the graphic hole. Do not over tighten.

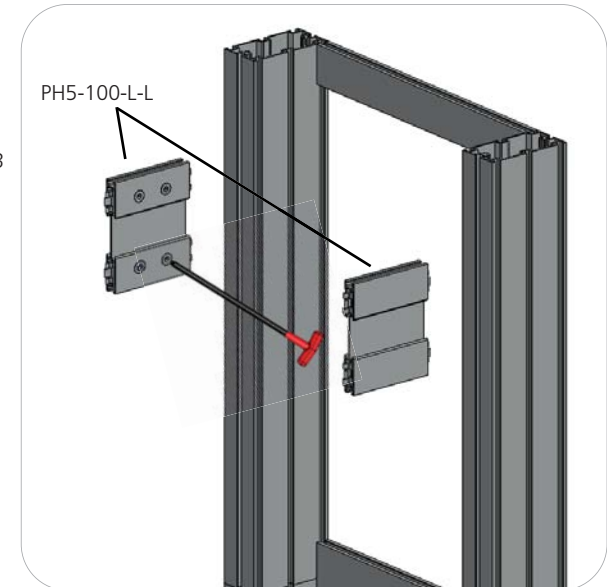

Kit Assembly

Step by Step

Step 5.

NOTE: Your main backwall assembly must be completed with graphics before completing this step of the monitor kit.

Lock your PM4S4-150 to the ends of the PH5-100-L-L. Do not over tighten.

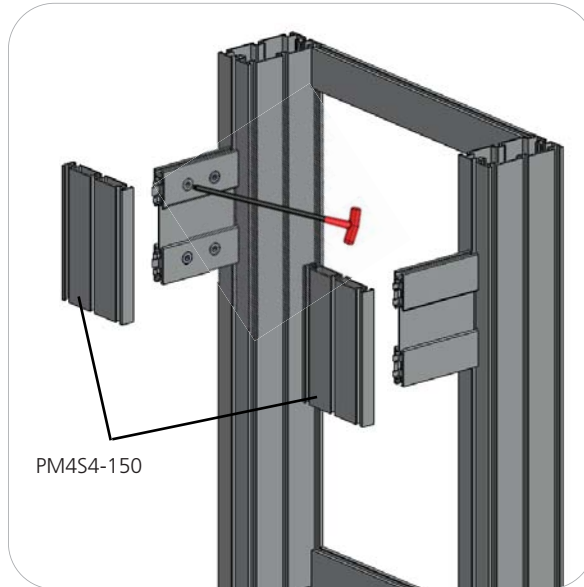
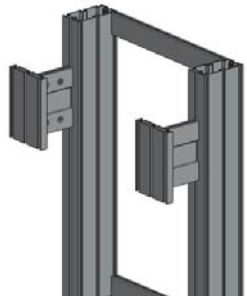

Step 6.

Set your monitor stand so that the extrusion arms fit through the graphic hole. Use the provided fastening hardware to complete your monitor stand. Slide the LN100 into the bottom center channel of the PM4S4-150. Next, slide the Square Head Bolt into the top center channel of the PM4S4-150. Apply the monitor bracket and spacer washer before fastening with the wingnut. Monitor mount may vary depending on size. Monitor not included.

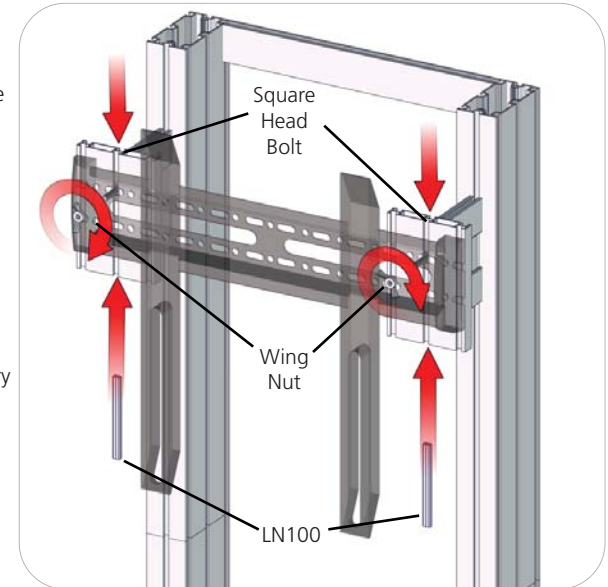

Step 7.

Setup is complete.



Monitor Bracket Instructions

Extrusion Channel Applications



EXT-SM-MB

Sizes: 17" - 37"

Max weight varies per application



EXT-M-MB

Sizes: 32" - 55"

Max weight varies per application



EXT-LG-MB

Sizes: 40" - 65"

Max weight varies per application

Included hardware:

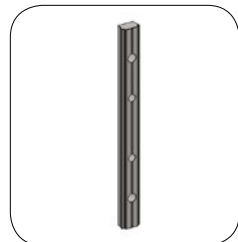

LN-100

x2



LN-LCD-SCW

x2

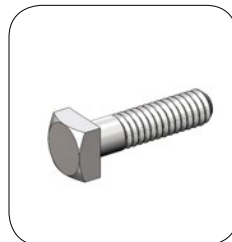

Square Bolt

x2

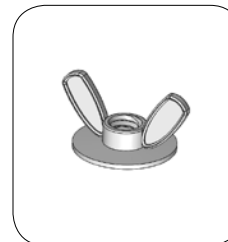

Wingnut

x2