

EZ Fold All-In-One™

Thank you for purchasing the EZ Fold All-In-One™ TV Stand. This TV stand is designed to accommodate flat panel TVs from to 28" to 70" diagonal weighing up to 90 Lbs.

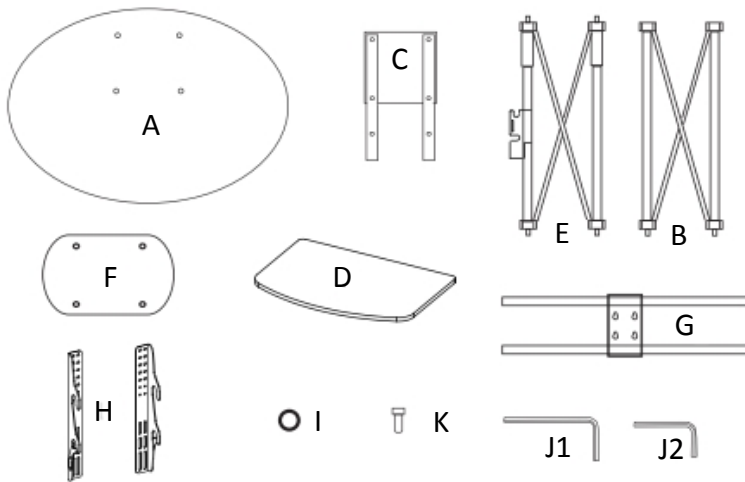

Name	Part	Qty.
Base	A	1
Bottom Truss	B	1
Center Plate and Shelf Bracket	C	1
Center Shelf and Screws	D	1
Top Truss	E	1
Top Component Shelf	F	1
Mounting Rails	G	2
Hanger Brackets	H	2
O-Rings	I	8
Allen Wrench J1 & J2	J	2
Interface Screws	K	12

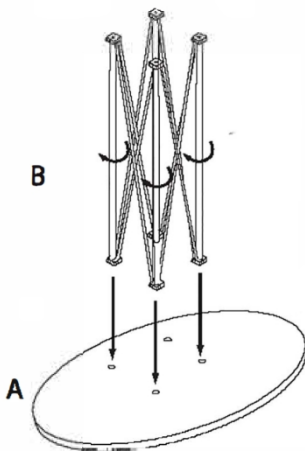
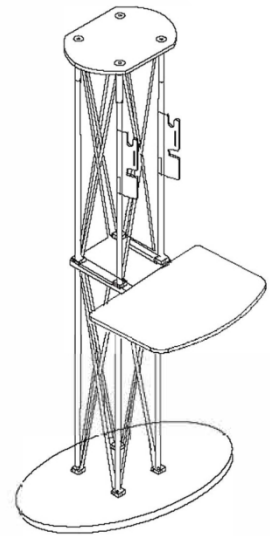

Step 1

Unfold Truss (B) and line up screws on truss (B) with holes on Base (A). Twist Truss column clockwise just above screws to screw Truss onto Base (A). Twist each column approximately 3 times around and repeat for each screw until complete.

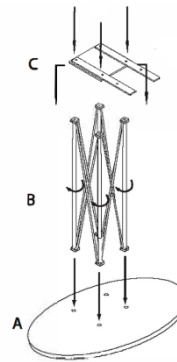

Step 2

Place Center Plate and Shelf Bracket (C) on top of Truss (B) with shelf brackets facing toward front.

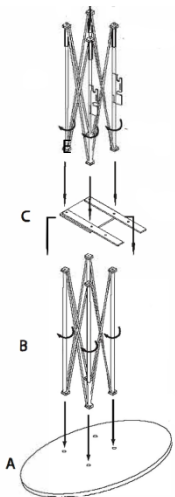

Step 3

Unfold Truss (E) and line up screws on truss (B). Twist Truss columns clockwise just above screws to screw Truss into Truss (B). Twist each column approximately 3 times around and repeat for each screw until complete.

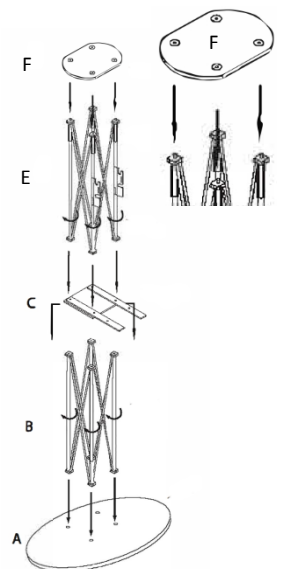

Step 4

Place top Component Shelf (E) on top of Truss (E) screws. Twist Top of Truss columns clockwise just below screws to Secure Component Shelf (F). Twist each column approximately 3 times around and repeat for each screw until complete.

Attach center shelf with provided thumb screws.

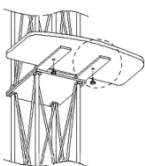

Step 5

Attach Center Shelf (D) to Shelf Bracket (C) with provided thumb screws .

VESA Interface 100x100 to 400x400 Installation

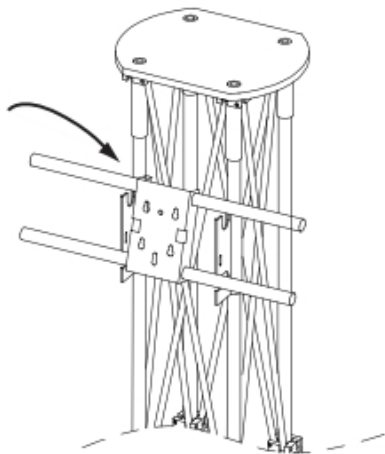

Place Mounting Rails (G) onto rail holding brackets of top Truss Section (E). Turn knob on rail holder and slide lock down into place and tighten (as shown below)

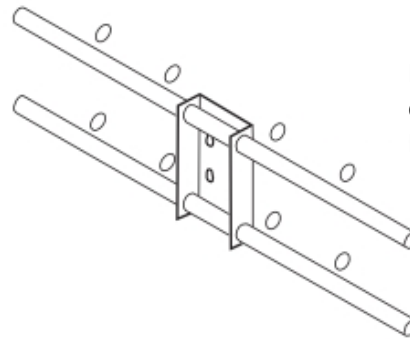
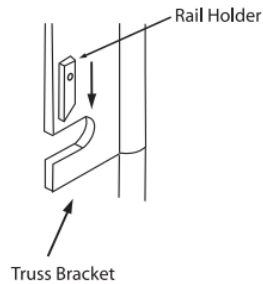

Place O-Rings (I) on to Mounting Rails (G)

Attaching Hanger Brackets to TV

Attach Hanger Brackets (H) on to back of the TV using provided Interface Screws (K) using the holes furthest from the hook.

Note: Multiple size screws are provided that fit the majority TV's. Only 4 screws are required for mounting.

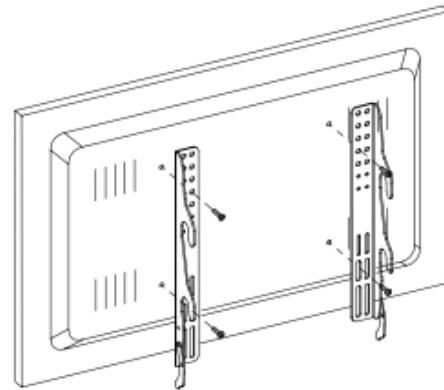

Placing TV on Mounting Rails

NOTE: We recommend that 2 people do this step depending on the size and weight of your TV.

Remove screw and lower Flag Lock into down position.

Center TV on Truss and lift and hook Hanger Brackets (H) on to Mounting Rails (G).

Lift Flag Lock into place insert and tighten locking screw.

Place last the 4 O-Rings on to Mounting Rails just outside Hanger Brackets (H) as shown in image 2

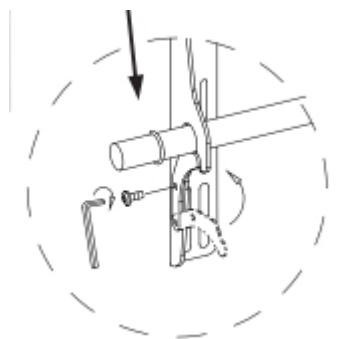
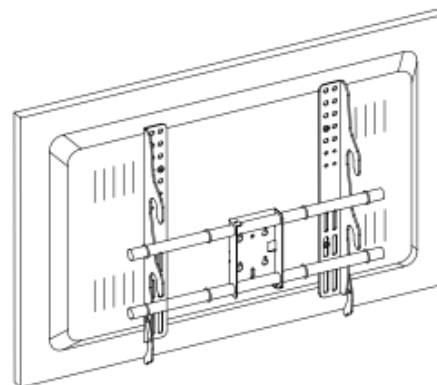

Image 2