

Formulate Designer Series 10' Backwall - Kit 05

FMLT-DS-10-05

Formulate™ Designer Series 10ft displays have unique stylistic features and shapes, are portable and easy to assemble. The aluminum tube frame features snap button and/or spigot connections and zipper pillowcase fabric graphics. All displays come in portable, wheeled transit cases. Simply pull the pillowcase fabric graphic(s) over the frame and zip.



features and benefits:

- Premium aluminum tube frames with spigot assembly
- Easy to store and ship
- Quick to set up
- Weighted feet for added stability
- Three zipper pillowcase fabric graphics
- Lifetime limited hardware warranty against manufacturer defects

dimensions:

Hardware	Graphic
<p>Assembled unit: 115.24"w x 98.27"h x 17.98"d 2927mm(w) x 2496mm(h) x 457mm(d)</p> <p>Approximate weight with cases: 66 lbs / 29.9 kgs</p>	<p>Refer to related graphic template for more information.</p> <p>Visit: www.exhibitors-handbook.com/graphic-templates</p>
Shipping	
<p>Packing case(s): 1 OCE Case</p> <p>Shipping dimensions: OCE: Expandable case length (l) may vary 40" - 66"l x 18"w x 18"h 1016mm-1677mm(l) x 458mm(w) x 458mm(h)</p> <p>Approximate total shipping weight (includes cases & graphics): 79 lbs / 35.8 kgs</p>	
	additional information:
	<p>Graphic material: dye-sublimation zipper pillowcase fabric</p>

We are continually improving and modifying our product range and reserve the right to vary the specifications without prior notice. All dimensions and weights quoted are approximate and we accept no responsibility for variance. E&OE. See Graphic Templates for graphic bleed specifications.

Included In Your Kit

Tools, Components, Tube & Connectors



ALLEN KEY SET x1



ES30 x26

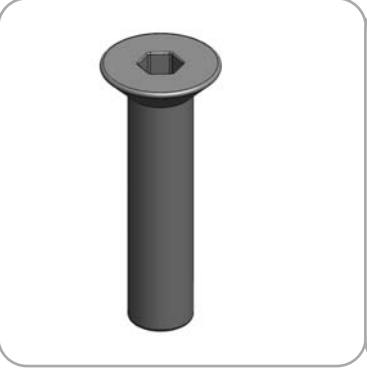

LN114-SCRW x4



ES30-90B x2



LN114-S3 x2



LN114-S2-450 x2



DS-10-05-T17 x1

Graphics



FMLT-DS-10-05-A-G x1

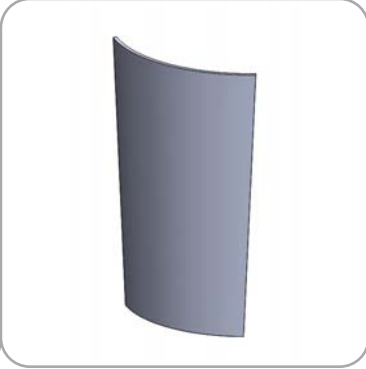

FMLT-DS-10-05-B-G x1



FMLT-DS-10-05-C-G x1

Included In Your Kit

Tubes



DS-10-05-T1 x2



DS-10-05-2-T2 x1



DS-10-05-T3 x4



DS-10-05-T4 x1

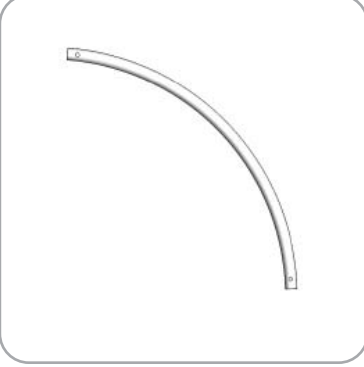

DS-10-05-T5 x2



DS-10-05-T6 x1



DS-10-05-T7-x4



DS-10-05-T8 x1

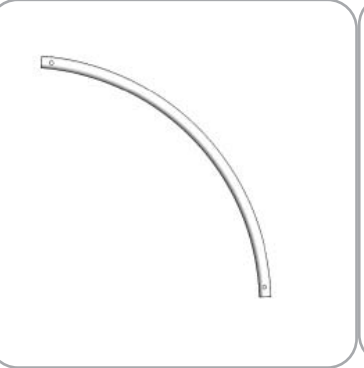

DS-10-05-T9 x1



DS-10-05-T10 x1



DS-10-05-T12 x1



DS-10-05-T13 x1



DS-10-05-T14 x1



DS-10-05-T15 x1



DS-10-05-T16 x1

Exploded View

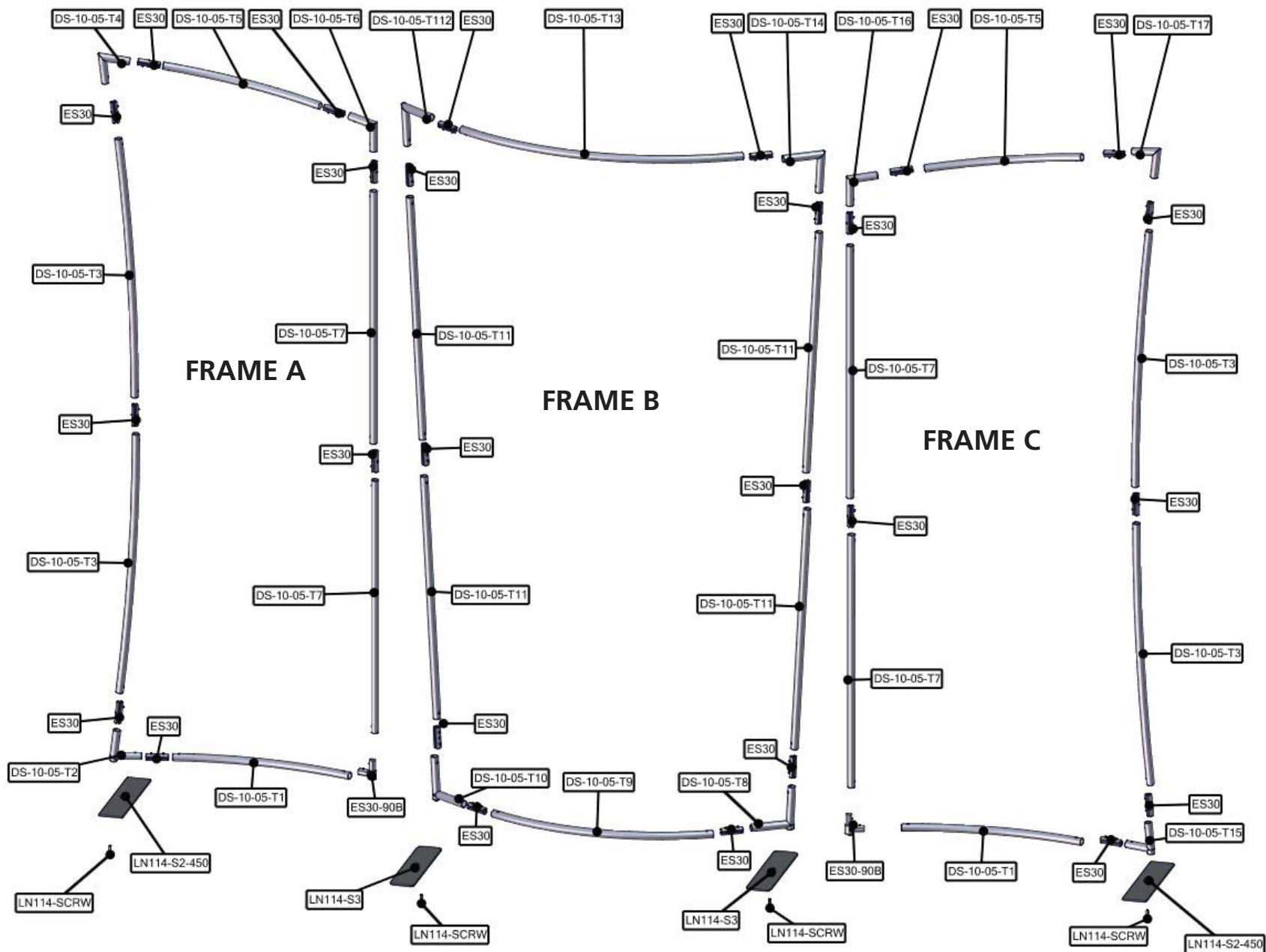

Labeling Diagram

FMLT-DS-10-05

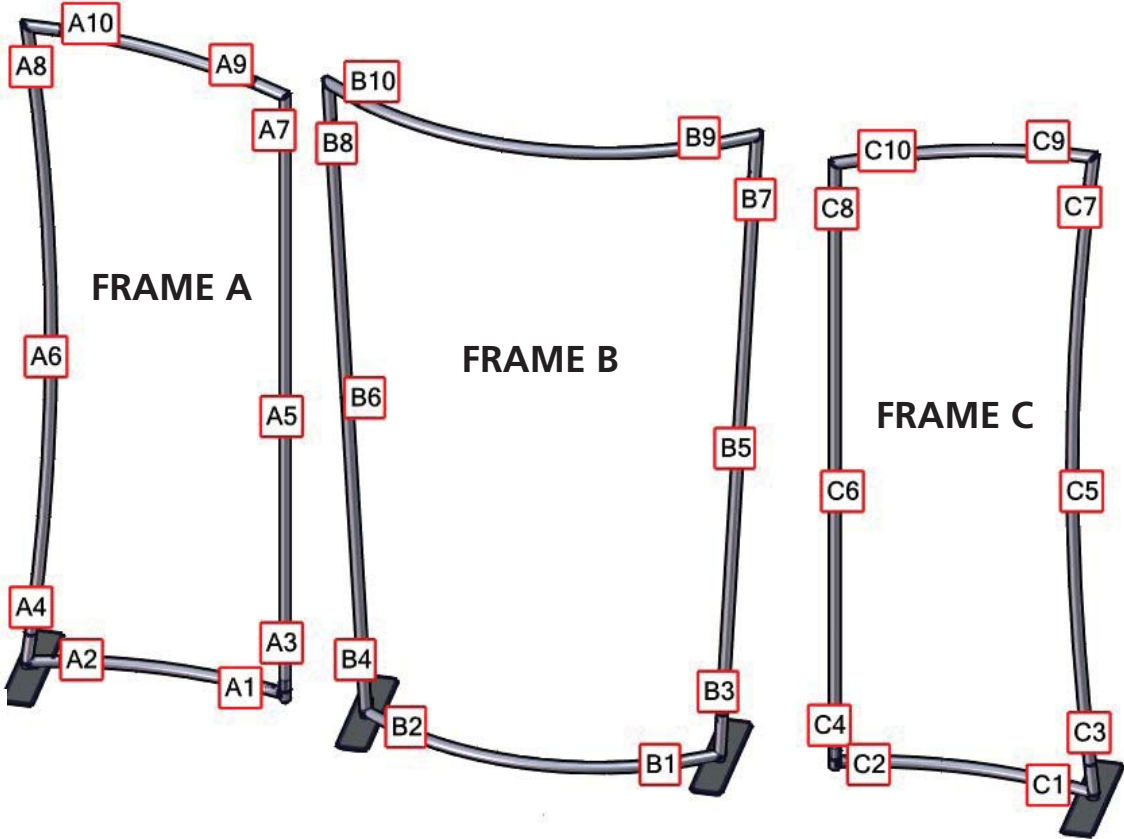

OVERHEAD VIEW

Connection Methods

Formulate™ structures use a number of different yet simple connection methods. Your kit will include one or more of the connection methods shown below. Steps within the Kit Assembly will reference a specific method for each connection point.

Connection Method 1: ES30 / ES50 / ES75

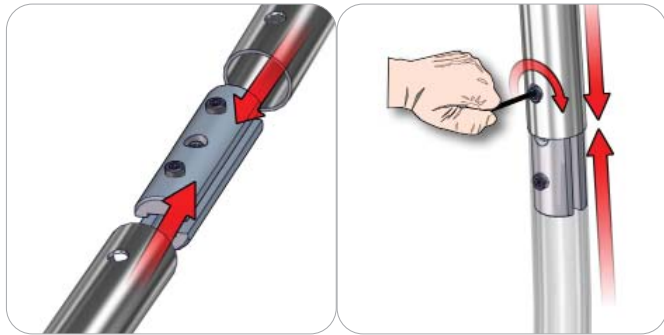

Compress the unlocked connector and slide one tube onto each end. Lock both screws carefully using your allen key tool. Be sure to lock securely, but do not overtighten.

Connection Method 2: Snap Buttons & Swage

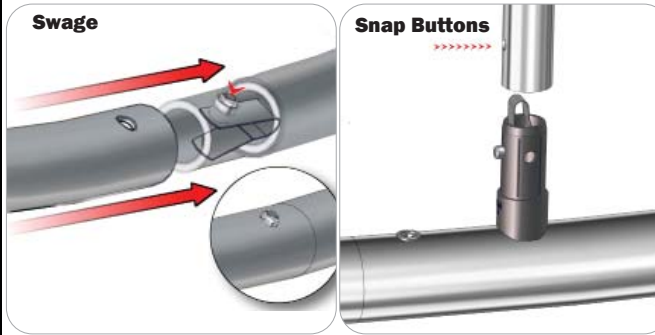

Locate the snap button on the connector or swage tube. Locate the hole on the corresponding tube. Press the snap button with your thumb and slide the tube and connector together so that the snap button snaps fully into the lock hole. To disassemble, press the snap button and pull apart.

Connection Method 3: ES30-90B / ES30-I / ES30-C

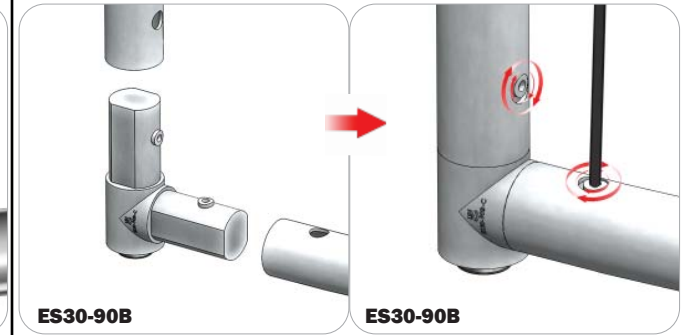

Compress one unlocked end of the connector and slide it through one tube end. Compress the other end of the connector and slide the second tube on. Lock both screws carefully using your allen key tool. Be sure to lock securely, but do not overtighten.

Connection Method 4: Tube Clamps

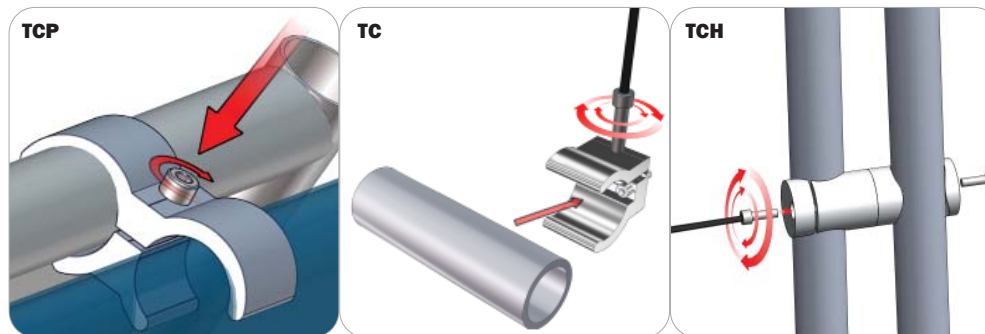

Be sure to fully assemble all frames before using clamps. With the clamp unlocked, place one tube of the first frame into the mouth of the clamp. Place the second tube (if applicable) into the second mouth of the clamp. With both frame's tubes in the clamp, be sure to lock securely, but do not overtighten.

Kit Assembly

Step by Step

Step 1.

Gather the components necessary for assembling Frame A and lay them flat on the floor. Assemble in the order the Labeling Diagram instructs.

Please reference Connection Methods 1 and 3 for more details.

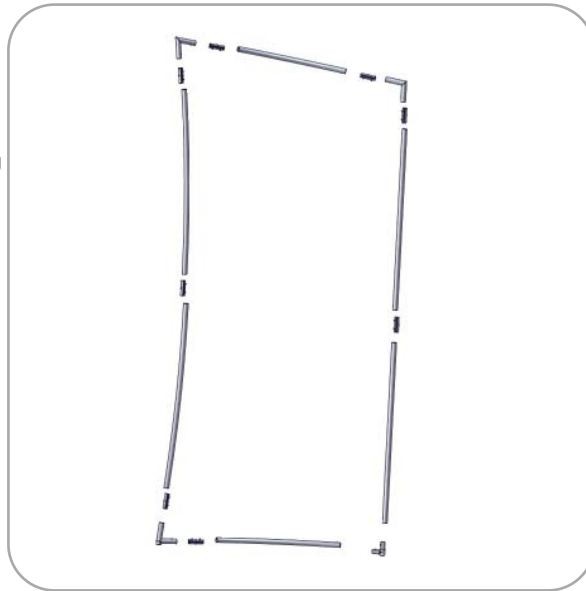

Step 2.

Gather the components necessary for assembling Frame B and lay them flat on the floor. Assemble in the order the Labeling Diagram instructs.

Please reference Connection Methods 1 and 3 for more details.

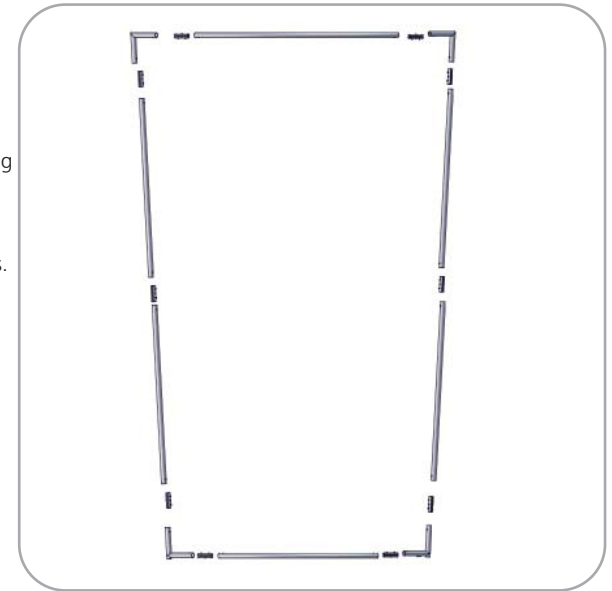

Step 3.

Gather the components necessary for assembling Frame C and lay them flat on the floor. Assemble in the order the Labeling Diagram instructs.

Please reference Connection Methods 1 and 3 for more details.

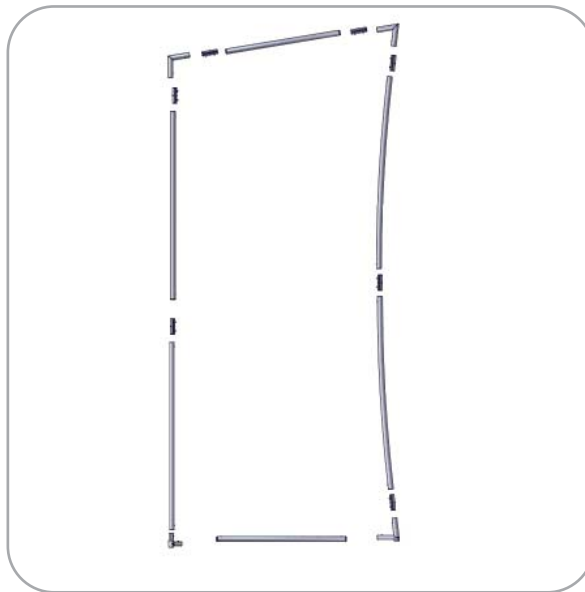

Step 4.

With Frame A laying flat on the floor, locate your pillowcase A graphic. With the pillowcase unzipped, encase Frame A by covering the Frame from top to bottom.

Zipper located to the right side and bottom of Graphic A

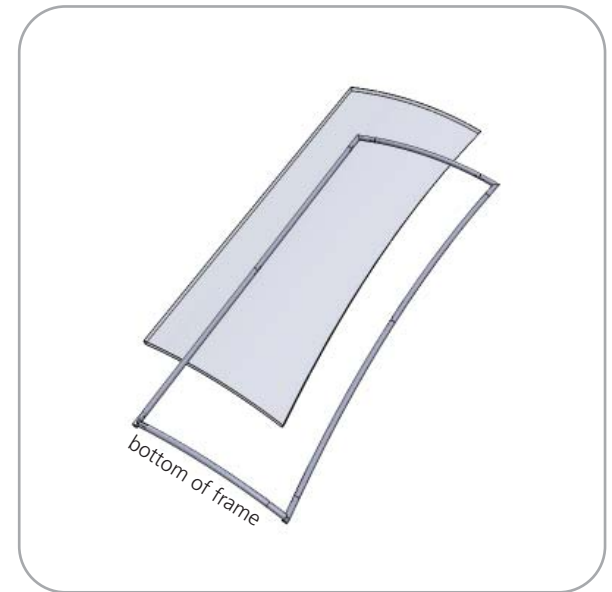

Kit Assembly

Step by Step

Step 5.

With Frame B laying flat on the floor, locate your pillowcase B graphic. With the pillowcase unzipped, encase Frame B by covering the frame from top to bottom.

Zipper located to the side and bottom of Graphic B

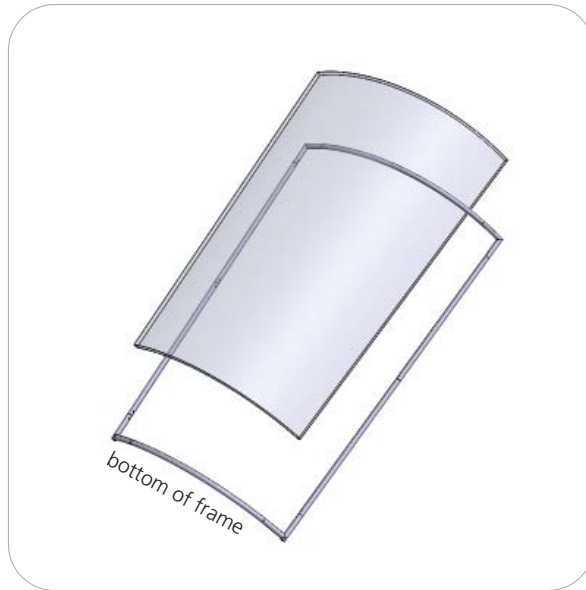

Step 6.

With Frame C laying flat on the floor, locate your pillowcase C graphic. With the pillowcase unzipped, encase Frame C by covering the frame from top to bottom.

Zipper located to the side and bottom of Graphic C

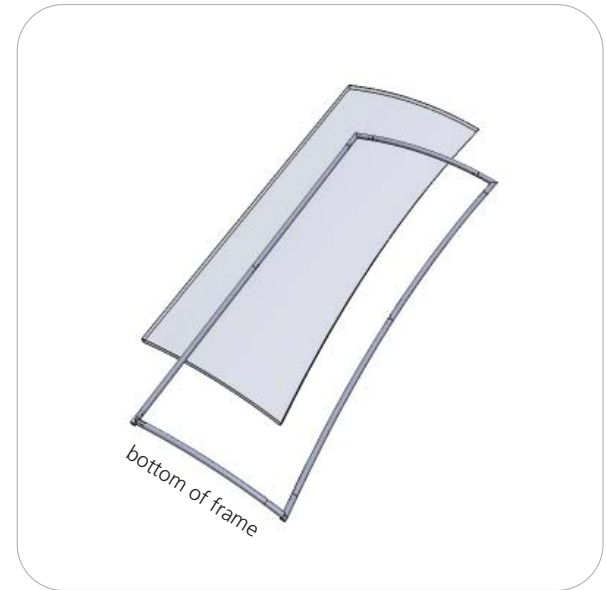

Step 7.

Gather both LN114-S2-450 assemblies, and (2) LN114 screws. Attach the foot to the left side of Frame A and right side of Frame C, in order as seen in the image to the right.



Step 8.

Gather both LN114-S3 assemblies, and (2) LN114 screws. Start by setting the hub on the foot into the ES30-90B. Next screw the foot and M10 spacer into Frame B in the order shown on the right. Tighten the screw on the ES30-90B to lock in place.

